

MULTISTAGE SPLIT CASE PUMPS

420 SERIES

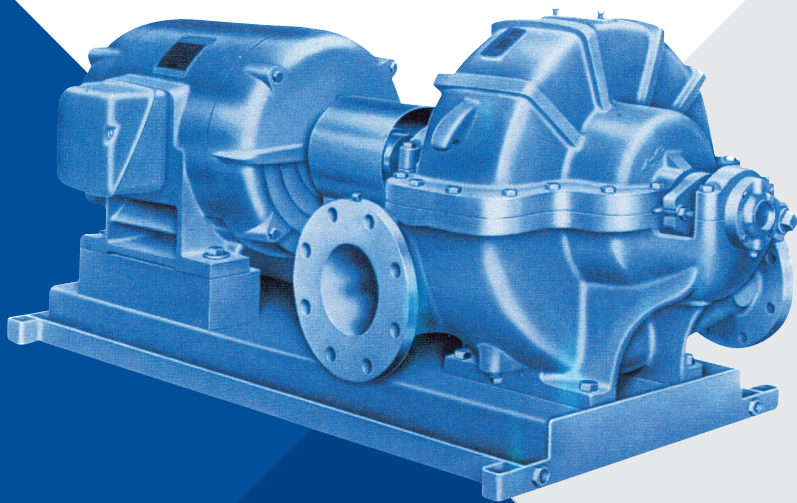

MODEL 421

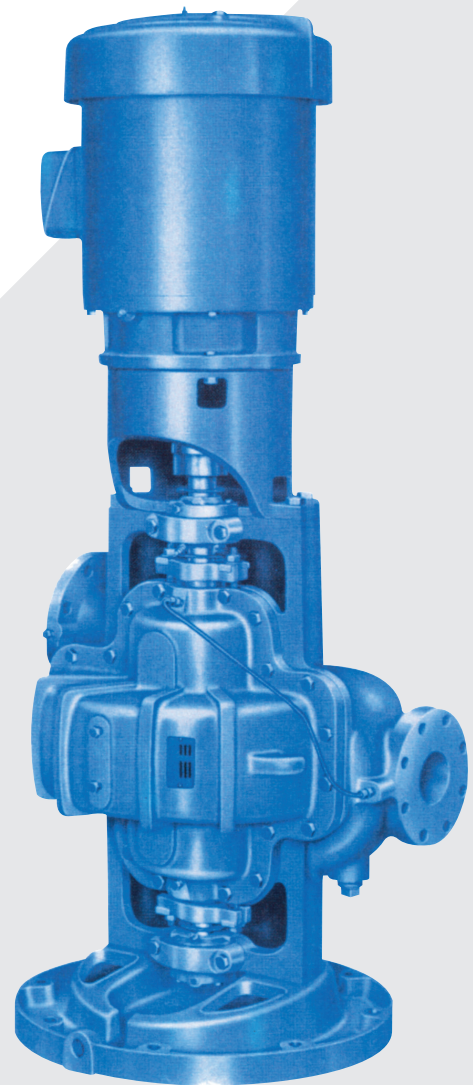

MODEL 423

PENTAIR® AURORA® 420 SERIES MULTISTAGE SPLIT CASE PUMPS

Capacities to 1800 GPM (409 m³/hr)

Heads to 600 Ft. (183 m)

Temperatures to 275°F (135°C)

RELIABLE PERFORMANCE IN TOUGH APPLICATIONS

Multi-stage split case pumps are trusted around the world to provide high pressure and power and greater energy efficiency for demanding municipal, industrial and commercial water systems. When single-stage pumps aren't sufficient, multi-stage pumps offer the flow rates and pressure ranges required in high head applications.

Aurora 420 Series Pumps were designed with quality and reliability in mind. They were engineered to maximize the life of bearings, pumps, and other key components. This ensures they perform consistently and efficiently, year after year, in demanding applications.

MODEL 421

Horizontally baseplate mounted with a driver flexibly coupled to the pump. Recommended for installations with ample floorspace and no possibility of flooding.

MODEL 423

Vertically mounted with an elevated driver coupled directly to the pump through a flexible coupling. Recommended for installations with limited floorspace and marginal possibilities of flooding.

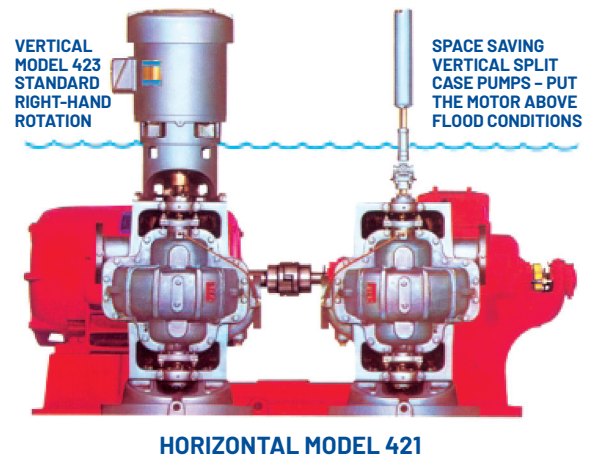
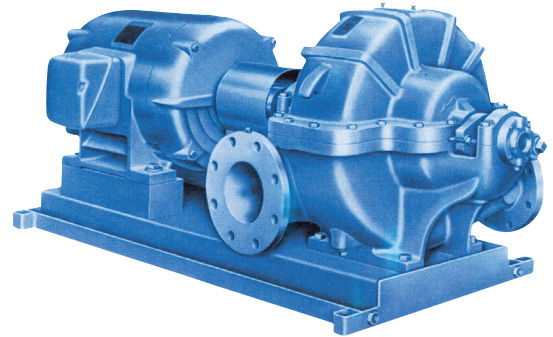
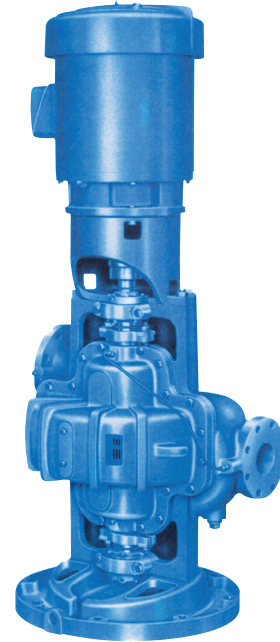

PUMP FEATURES

STANDARD FEATURES

- ◆ Bronze fitted pump construction
- ◆ Bronze shaft sleeves
- ◆ Dynamically balanced impellers
- ◆ Bronze case wearing rings
- ◆ Multivolute on 2" and larger pumps
- ◆ Stainless steel impeller key
- ◆ Regreaseable ball bearings
- ◆ Single row ball bearing (inboard)
- ◆ Double row ball bearing (outboard)
- ◆ Coupling guard (Model 421)
- ◆ Mechanical seals – single unbalanced (Model 423)
- ◆ Interwoven, graphite/Teflon™ lubricated acrylic yarn packing rings (Model 421)
- ◆ Internal bypass between casing and stuffing box (first stage)
- ◆ 125# suction, 250# discharge ASA flanges
- ◆ 250 psi case working pressure
- ◆ Carbon steel shaft
- ◆ Stuffing box bushings
- ◆ Lifting lugs
- ◆ Hydrostatic test
- ◆ Cast integral bearing arms
- ◆ Water slingers and grease seals

OPTIONAL FEATURES

- ◆ All iron or special alloy pump construction
- ◆ Hardened 440C stainless steel shaft sleeves (packing only)
- ◆ 316 stainless shaft sleeves (mechanical seals)
- ◆ Impeller wearing rings
- ◆ Oil lubricated ball bearings (Model 421 Horizontal Pump)
- ◆ Mechanical seals, single unbalanced (Model 421)
- ◆ Stainless steel shaft
- ◆ External bypass between casing and stuffing box
- ◆ Steel drip rim, formed steel or fabricated steel bases
- ◆ Double extended shaft (Model 421)
- ◆ Right- or left-hand rotation
- ◆ Certified performance test
- ◆ Packing with lantern ring (Model 421)
- ◆ 250# ASA suction and discharge flanges
- ◆ Water cooled bearing

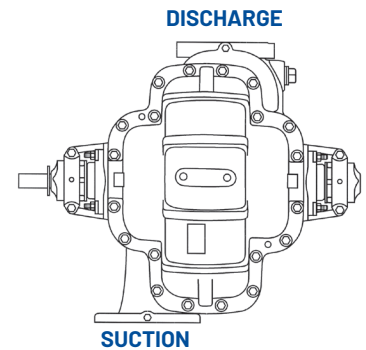

**STANDARD
RIGHT-HAND ROTATION**

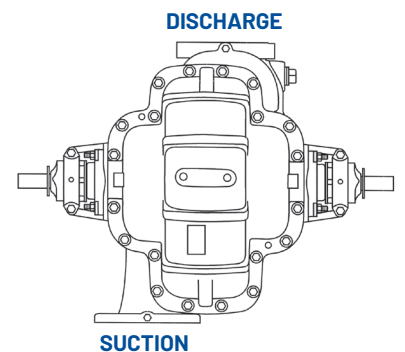

**OPTIONAL DUAL DRIVE
RIGHT-HAND ROTATION**

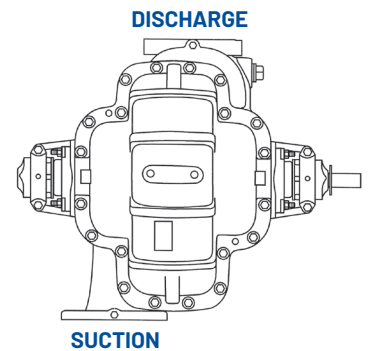

**OPTIONAL
LEFT-HAND ROTATION**

HORIZONTAL PUMP FEATURES

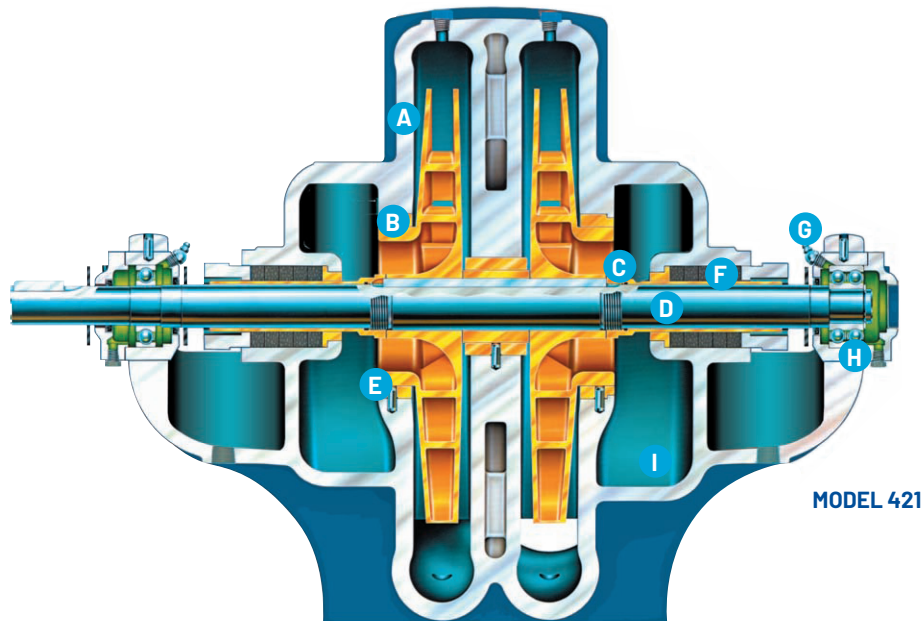

A. SPLIT CASE DESIGN

- ◆ Design makes service or inspection simple through removal of upper casing without disturbing suction and discharge piping and alignment
- ◆ Computer-machined major components with 360-degree registered fits help assure concentricity of all parts

B. DYNAMICALLY BALANCED IMPELLER

- ◆ Keyed to the shaft and secured by adjustable shaft sleeves
- ◆ Opposed suction design balances hydraulic thrust loads
- ◆ Vacuum cast process and proven design provides superior efficiency and performance

C. BRONZE SHAFT SLEEVE

- ◆ Slip fit over the shaft, keylocked and extends the entire length of each stuffing box to prevent shaft wear
- ◆ Shaft sleeves and impeller are sealed by Teflon™ coated steel gaskets to prevent shaft corrosion, to help reduce likelihood of shaft corrosion, which helps avoid the need for high-cost, special stainless or Monel® shafts

D. LEFT HAND ROTATION

- ◆ Available with standard parts – tandem drive pumps require different shaft

E. CASE WEARING RINGS

- ◆ Prevent wear on the pump casing
- ◆ Easy and cost-effective to replace

F. INTERCHANGEABLE STUFFING BOX

- ◆ Allows use of mechanical seals or packing (standard on horizontal pumps)
- ◆ Optional lantern rings with internal water seal passages between the casing and stuffing box to prevent damage
- ◆ Mechanical seals have carbon against ceramic face
- ◆ 303 stainless steel parts and Buna-N® elastomers help ensure long life
- ◆ Several mechanical seal options available

G. GREASE LUBRICATION

- ◆ Purges old grease from bearing
- ◆ Oil lubrication optional on horizontal pumps
- ◆ Fittings conveniently located provide quick access and positive bearing lubrication
- ◆ Oil seals and nonsparking neoprene rotating slingers protect bearings during operation and washdowns

H. BEARINGS

- ◆ Provide 50,000-hour minimum life at maximum load
- ◆ Double row thrust ball bearing standard on all models
- ◆ Short bearing span holds shaft deflection to .002" at face of stuffing box at maximum load
- ◆ Integral bearing arms eliminate bearing misalignment and simplify service

I. CERTIFIED PERFORMANCE

- ◆ Certification with positive suction pressure or with a suction lift available on each pump for customer approval – pumps are all hydrostatically tested

VERTICAL PUMP FEATURES

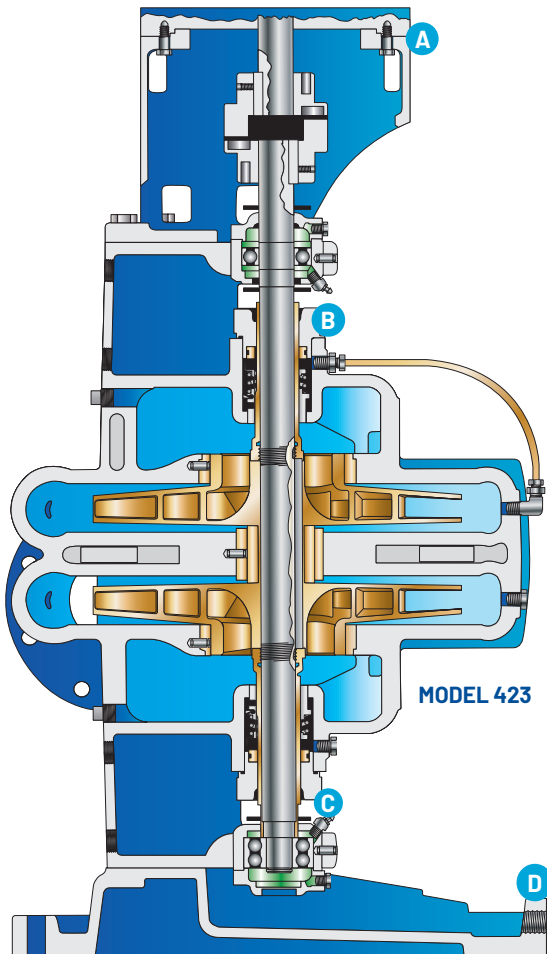

KEY FEATURES

A. COUPLING ALIGNMENT

- ◆ Mounting bracket is rabbet fitted to the motor to provide long life and proper performance

B. MECHANICAL SEALS

- ◆ Standard construction includes carbon against ceramic face for optimum hot water performance
- ◆ 303 stainless steel parts and Buna-N® elastomers provide long life

C. BEARING PROTECTION

- ◆ Grease seals and water slingers protect the bearings from contamination

D. CAST IRON DRIP RIM BASE

- ◆ Mounting base helps assure accurate positioning of the pump
- ◆ Integral drip rim controls condensation and leakage

E. STANDARD EXTERNAL UPPER SEAL FLUSH

- ◆ Helps eliminate air entrapment on the upper mechanical seal and lengthens seal

BENEFITS

Vertical pumps fit into less floorspace – typically half of that required by a comparable horizontal split case pump.

The in-line piping arrangement allows piping in any direction.

The elevated motor helps protect against potential flooding.

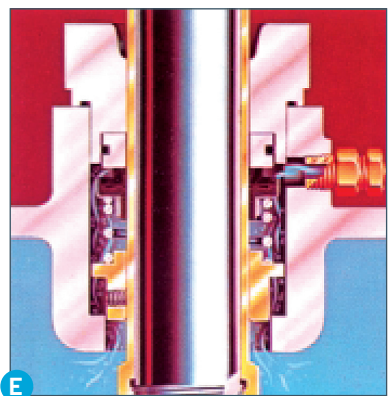

EXTERNAL UPPER SEAL FLUSH

RANGE CHARTS

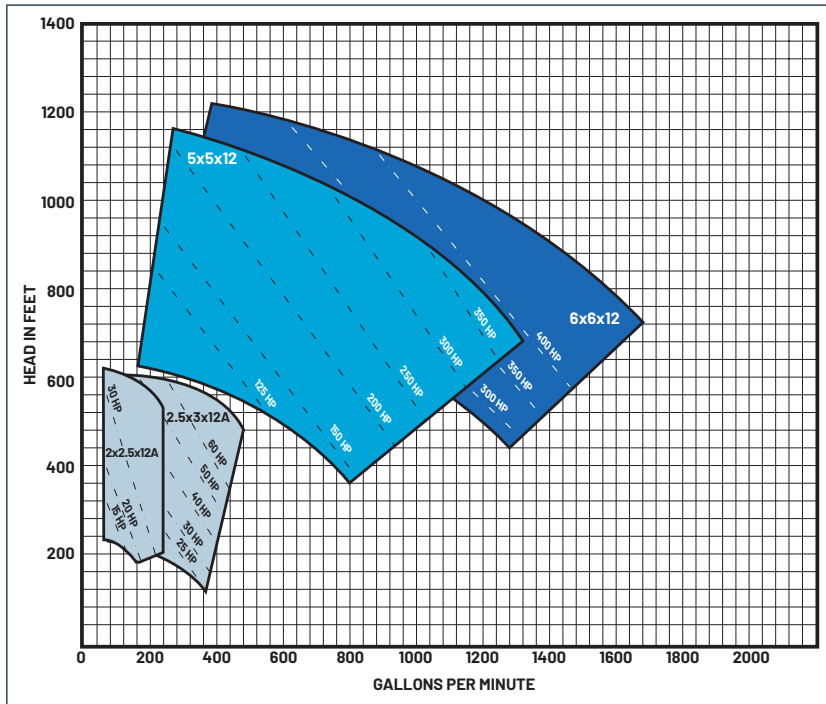

3600 RPM

Individual performance curves should be checked for final selection.

For selections not shown on this chart, please refer to the factory.

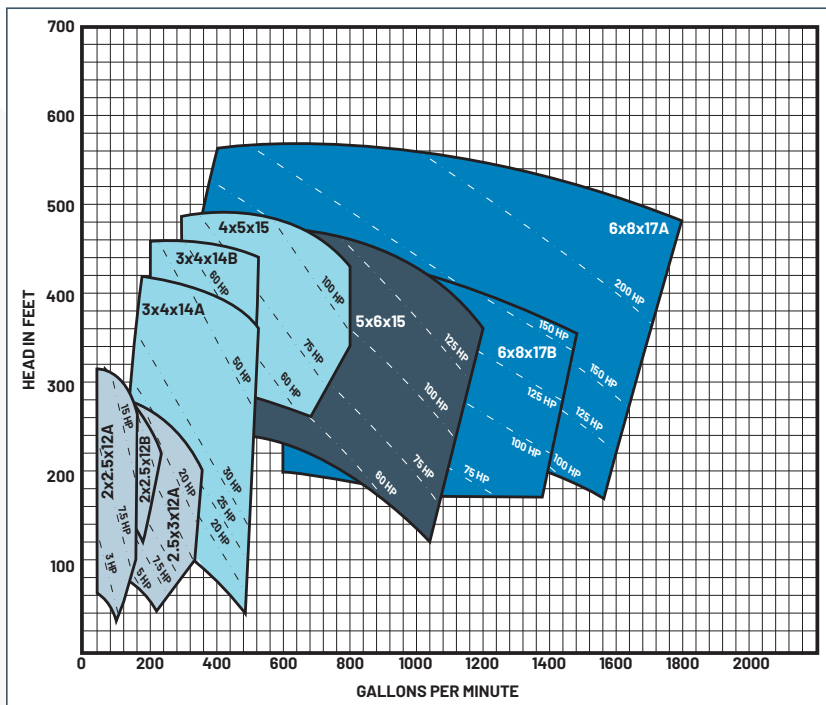
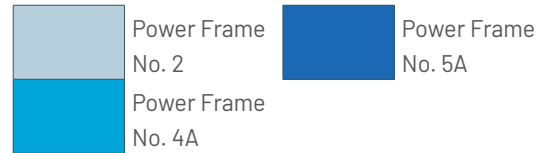

1800 RPM

Individual performance curves should be checked for final selection.

For selections not shown on this chart, please refer to the factory.

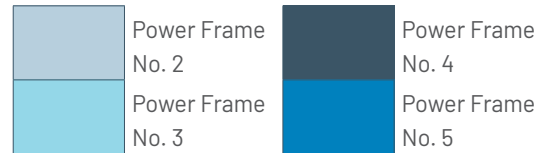

RANGE CHARTS

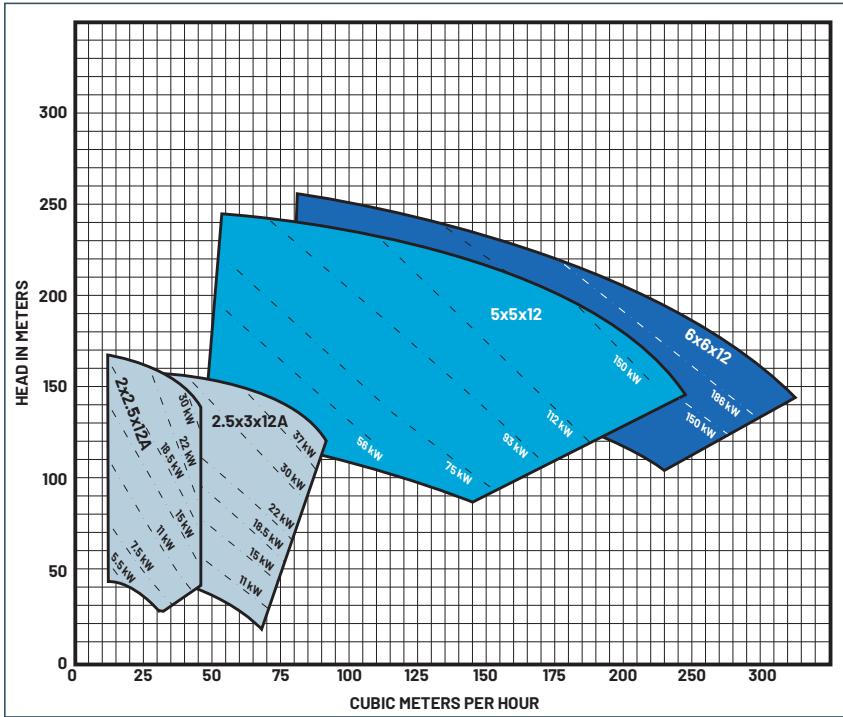

3000 RPM

Individual performance curves should be checked for final selection.

For selections not shown on this chart, please refer to the factory.

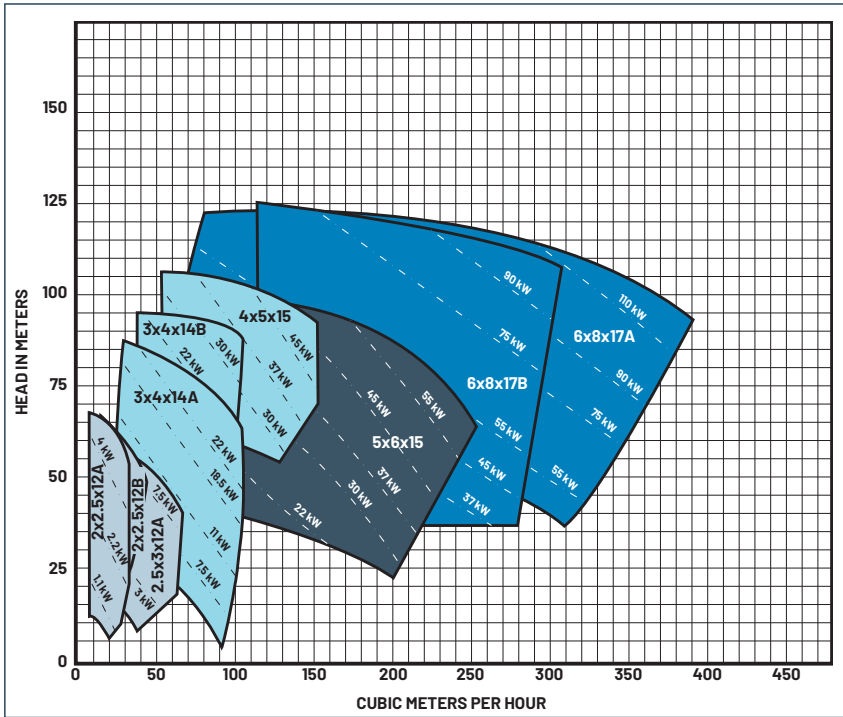
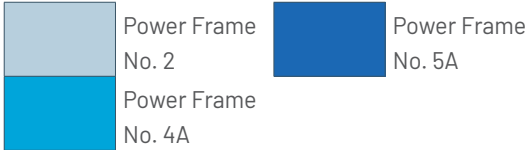

1500 RPM

Individual performance curves should be checked for final selection.

For selections not shown on this chart, please refer to the factory.

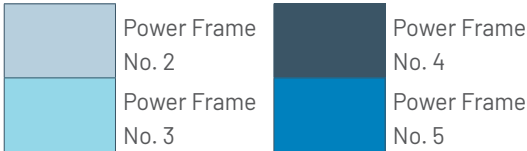

PUMP DIMENSIONS

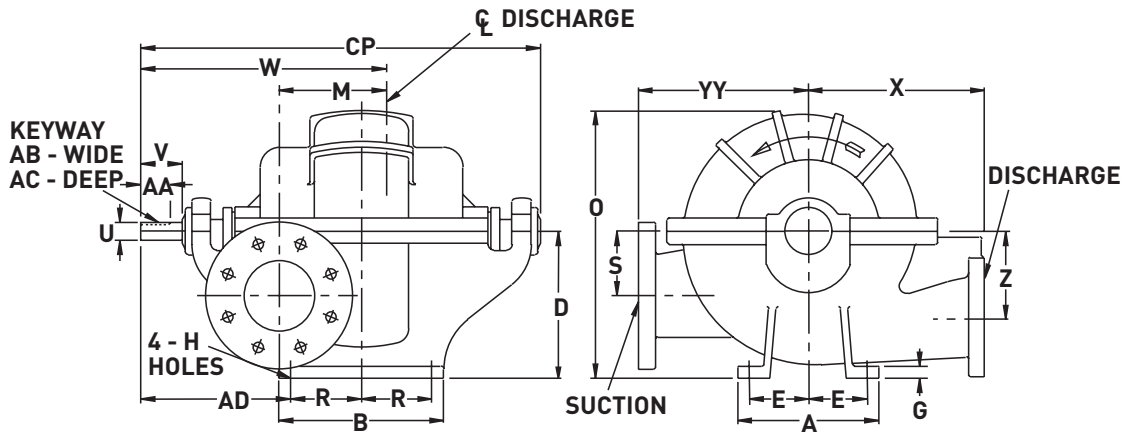

MODEL 421 - RIGHT-HAND ROTATION

Model	Pump Size			Power Series	A	B	D	E	G	H	M	O	R	S	U	V	W	X	Z	AA	AB	AC	AD	CP	YY
	Disch.	Suction	Case Bore																						
2x2.5x12A/ 2x2.5x12B	2	2-1/2	12	2	8 (203)	10 (254)	9 (229)	3-1/2 (89)	3/4 (19)	5/8 (16)	4-3/4 (121)	19 (483)	4 (102)	4 (102)	1-1/8 (29)	2-3/4 (70)	15-3/4 (400)	10 (254)	5-1/2 (140)	2 (51)	1/4 (6)	1/8 (3)	10-1/2 (268)	26-1/4 (667)	10-1/4 (260)
2.5x3x12A	2-1/2	3	12	2	8 (203)	10 (254)	9 (229)	3-1/2 (89)	3/4 (19)	5/8 (16)	5-3/8 (137)	19 (483)	4 (102)	4 (102)	1-1/8 (29)	2-3/4 (70)	15-7/8 (403)	11 (279)	5-1/2 (140)	2 (51)	1/4 (6)	1/8 (3)	10-1/2 (268)	26-1/4 (667)	11 (279)
3x4x14A/ 3x4x14B	3	4	14	3	10 (254)	12 (305)	10 (254)	4-1/4 (108)	7/8 (22)	3/4 (19)	6-3/4 (171)	21 (533)	5 (127)	4-1/2 (114)	1-3/8 (35)	3 (76)	18-3/4 (476)	12 (305)	6 (152)	2 (51)	3/8 (10)	3/16 (5)	12 (305)	31 (787)	12-3/8 (314)
4x5x15	4	5	15	3	10 (254)	12 (305)	11 (279)	4-1/4 (108)	7/8 (22)	3/4 (19)	7-1/8 (181)	23 (584)	5 (127)	5 (127)	1-3/8 (35)	3 (76)	18-7/8 (479)	13 (330)	6-1/2 (165)	2 (51)	3/8 (10)	3/16 (5)	12 (305)	31 (787)	13-1/2 (343)
5x5x12	5	5	12	4A	15 (381)	16 (305)	14 (356)	6-1/2 (165)	1 (25)	7/8 (22)	6-5/8 (168)	24-1/4 (616)	7 (178)	7 (178)	1-1/2 (38)	3-5/8 (92)	20-7/8 (530)	13 (330)	7 (178)	2-1/2 (64)	3/8 (10)	3/16 (5)	12-1/2 (318)	35-3/8 (899)	13 (330)
5x6x15	5	6	15	4	12 (305)	14 (356)	12-1/2 (318)	5 (127)	1 (25)	7/8 (22)	9-1/8 (232)	24-1/2 (622)	6 (152)	5-1/2 (140)	1-1/2 (38)	3-1/2 (89)	21-1/8 (537)	15 (381)	7-1/2 (191)	2 (51)	3/8 (10)	3/16 (5)	13 (330)	34-1/2 (876)	15-7/16 (392)
6x6x12	6	6	12	5A	16 (406)	19 (483)	15 (381)	7 (178)	1 (25)	7/8 (22)	7-1/2 (191)	26-1/4 (667)	8-1/2 (216)	8 (203)	1-3/4 (44)	4 (102)	22-7/8 (581)	14 (356)	8 (203)	2-3/4 (70)	3/8 (10)	3/16 (5)	12-3/4 (324)	38-1/2 (978)	14 (356)
6x8x17A/ 6x8x17B	6	8	17	5	12 (305)	14 (356)	14-3/4 (375)	5 (127)	1 (25)	7/8 (22)	11 (279)	28-1/4 (718)	6 (152)	7 (178)	1-3/4 (44)	4 (102)	24-1/2 (622)	16 (406)	9 (229)	2-7/8 (73)	3/8 (10)	3/16 (5)	15 (381)	38 (965)	16-1/2 (419)
6x8x16/ 6x8x16B	6	8	16/ 16B	5	12 (305)	14 (356)	16.50 (419)	5 (127)	1 (25)	.88 (22)	10.50 (267)	33.50 (851)	6 (152)	8.25 (210)	1.75 (44)	4 (102)	23.63 (600)	19 (483)	7.75 (197)	2.88 (73)	3/8 (10)	3/16 (5)	15 (381)	37.88 (962)	17 (432)

PUMP DIMENSIONS

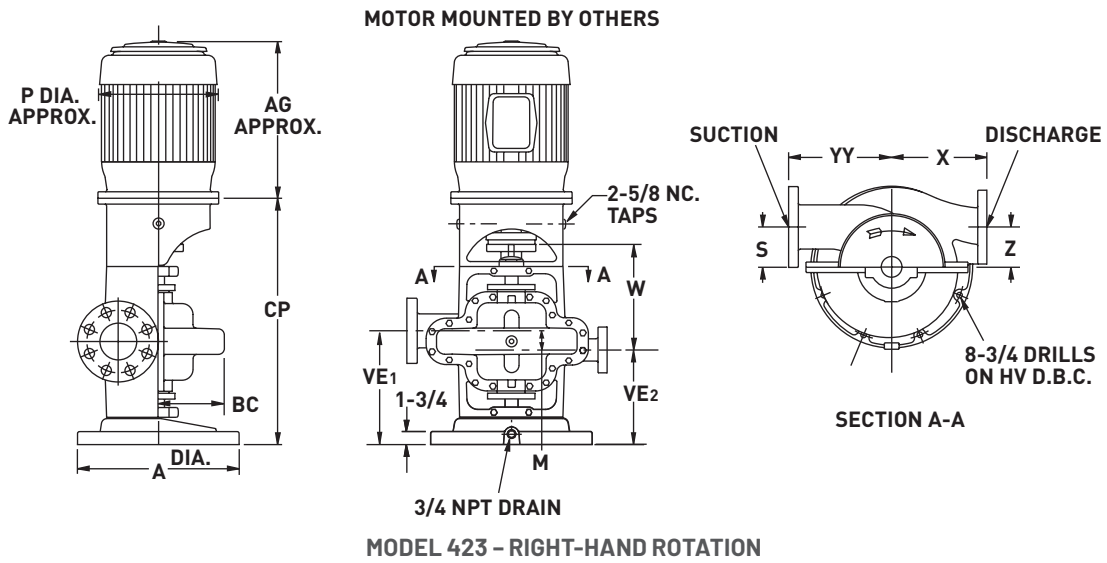

Model	Pump Size			Power Series	A	M	S	W	Z	BC	CP		HV	VE	X	YY
	Disch.	Suction	Case Bore								143HP-256HP	284HP-404HP				
2x2.5x12A/ 2x2.5x12B	2	2-1/2	12	2	18 (457)	4-3/4 (121)	4 (102)	15-3/4 (400)	5-1/2 (140)	10 (254)	32-1/8 (816)	34 (864)	16-1/4 (413)	12-7/8 (327)	10 (254)	10-1/4 (260)
2.5x3x12A	2-1/2	3	12	2	18 (457)	5-3/8 (137)	4 (102)	15-7/8 (403)	5-1/2 (140)	10 (254)	32-1/8 (816)	34 (864)	16-1/4 (413)	12-3/4 (324)	11 (279)	11 (279)
3x4x14A 3x4x14B	3	4	14	3	22 (559)	6-3/4 (171)	4-1/2 (114)	18-3/4 (476)	6 (152)	11 (279)	37-3/8 (949)	39-3/4 (1010)	20 (508)	14-3/4 (375)	12 (305)	12-3/8 (314)

Frame	143 HP	145 HP	182 HP	184 HP	213 HP	215 HP	254 HP	256 HP	284 HP	286 HP	324 HP	326 HP	364 HP	365 HP	404 HP
P	8	8	10	10	11	11	13	13	16	16	18	18	20	20	22
AG	11	12	13	14	16	18	20	22	23	24	25	27	32	32	35

ENGINEERING SPECIFICATIONS

MODELS 421 AND 423 HORIZONTAL SPLIT CASE

Furnish and install as shown on the plans...right-hand (left-hand) Pentair® Aurora® model (horizontal-421)(vertical-423 flexible coupled) type split case, opposed suction, multistage centrifugal pump, Size ___ x ___ x ___ of bronze fitted (all bronze)(all iron)(stainless steel) construction. The pump shall be capable of delivering at design conditions a capacity of ___ GPM when operating against a total dynamic Head of ___ feet, with a temperature of ___ °F, specific gravity ___. Pump shall have minimum guaranteed efficiency at design capacity of ___ %. Pump must also be capable of delivering a maximum of ___ GPM when operating against a head of ___ feet, and at this condition shall have a minimum efficiency of ___ %. Minimum shut-off head acceptable will be ___ feet. Pump shall operate at a maximum synchronous speed of ___ RPM.

A unit operating at a lesser rotative speed will be considered, but in no event will a pump operating at more than the maximum speed specified be acceptable. The pump casing halves shall be of the inline piping design and will be constructed of Class 30 cast iron having a minimum tensile strength of 30,000 psi and shall be of sufficient thickness to withstand stresses and strains at full operating pressures.

Casings shall be subject to a hydrostatic pressure test at 150% of the specified duty point. Bearing housing supports, suction and discharge flanges shall be integrally cast with the lower half of the casing. Removal of the upper half of the casing must allow the rotating element to be removed without disconnecting the suction and discharge piping. The upper casing is to be dowel aligned to the lower casing.

Pump sizes 2" and larger are to be of the multivolute design. Drain openings must be provided in the bearing arms for removal of lubricating liquid. Impellers shall be of the enclosed, opposed suction type and shall be of vacuum cast bronze (___). Impellers shall be dynamically balanced and securely fastened to the shaft by key and screw locked shaft sleeves. The vanes shall be designed to reduce noise. The pump shaft shall be made of high grade SAE 1045 steel or equal, accurately machined to give a true running rotating element. The minimum dia. acceptable will be ___ ". The shaft shall be protected from wear by bronze (___) sleeves which are key locked and threaded so that the sleeves tighten with the rotation of the shaft. Teflon™ coated steel gaskets must be provided between the impeller hub and the shaft sleeves to prevent pumped liquid from corroding the shaft.

Pump shall be equipped with easily renewable bronze (___) casing rings (impeller wearing rings) so designed that hydraulic pressure will seat them against a shoulder in the pump case around the full periphery of the wearing ring. The wear rings will be locked in place by dowelling to prevent rotation. The rotating element shall be mounted in heavy duty grease lubricated ball bearings and shall be equipped with water slingers on side next to pump glands.

Bearing housings shall be so designed to flush lubricant through and provide continuous cleaning of bearing surfaces and protection against overheating. The bearing housings are to be of C.I. and shall be furnished with a set of regreaseable (optional oil lubricated on Model 421) bearings for both radial and thrust loads. The bearings shall have an average life of 50,000 hours and shall be mounted in machined, moisture and dust-proof housings. The housings are to have register fits and then be bolted to the pump casing to ensure permanent alignment.

ENGINEERING SPECIFICATIONS

MODEL 421

Stuffing boxes shall be placed on both sides of the pump centerline to seal the pump shaft. All packed pumps having a suction lift have a first-stage lantern ring connected to the pressure side of the pump by a cored passage in the parting flange of the pump. The stuffing boxes shall be equipped with heavy, cast, split glands with extra length for easy removal for packing inspection and maintenance. Pump and motor shall be mounted on a common heavy baseplate of (steel drip rim)(formed steel)(structural steel). Pump and motor must be checked for alignment after the pump base has been installed and grouted in place, in accordance with the standards of the Hydraulic Institute. There shall be no strain transmitted to the pumps.

MODELS 423

Mechanical seal boxes shall be placed on both sides of the pump centerline to seal the pump shaft. Each pump is to be furnished with mechanical seals with all metal parts to be 303 stainless steel with Buna-N® elastomers, ceramic seat and carbon washer. A bypass line must be provided for the upper seal between the seal faces and the discharge flange to assure adequate venting of the seal chamber and to provide lubrication. All pumps shall be provided with a cored passage in the parting flange of the pump to provide additional circulation to first-stage seal. The mechanical seal boxes shall be equipped with heavy, cast, one piece, O-ring sealed glands. The pump shall be supported by a cast iron drip rim base.

MODEL 423

Vertical flexible coupled pumps shall be furnished with a cast iron motor bracket which is to be bolted to the vertical casing. The motor bracket must be machined with a register fit to ensure proper alignment of motor and pump shaft.

MODELS 421 AND 423

The pumps shall be flexible coupled to a standard (horizontal) (vertical) NEMA® ____ hp, ____ phase, ____ hertz, ____ volts, ____ RPM (drip-proof)(tot. encl.)(hazardous location) motor.



800 Airport Road | North Aurora, IL, USA, 60542 | Ph: 630.859.7000 | pentair.com

All indicated Pentair trademarks and logos are property of Pentair. Third party registered and unregistered trademarks and logos are the property of their respective owners. Because we are continuously improving our products and services, Pentair reserves the right to change specifications without prior notice. Pentair is an equal opportunity employer.

Buna N® is the registered trademark of Pittway Corporation, Chicago.

Hydraulic Institute is a trademark of Hydraulic Institute, Inc.

Monel is a registered trademark of Special Metals Corporation.

NEMA® is the registered trademark and service mark of the National Electrical Manufacturers Association.

Teflon™ is a trademark of The Chemours Company FC, LLC.

©2022 Pentair. All Rights Reserved.

A-02-1018 (03-23-22)