

# WS-30E SERIES WATER CONDITIONERS

System Part Numbers:

WS-30E (120 VAC 50/60 Hz): EV9980-58

WS-30E (230 VAC 50 Hz): EV9980-59



## APPLICATIONS

- ◆ Cold water fed warewashing
- ◆ Laundry - linen & uniform
- ◆ Boiler scale control
- ◆ Water heater scale protection/reduction
- ◆ General housekeeping
- ◆ Reverse osmosis pretreatment
- ◆ Espresso

## SYSTEM DESCRIPTION

Water conditioning for commercial applications configured as a single tank system with 3/4" porting.

## FEATURES • BENEFITS

- ◆ Hardness removal of 30,000 grains at flow rates up to 10 gpm (37.8 Lpm) continuous
- ◆ Advanced, user-friendly controls incorporate time-tested, hydraulically-balanced piston, seal and spacer design to pilot service flow and regeneration
- ◆ Pentair® Fleck® 5600-SXT meter-initiated control valve monitors water usage and minimizes salt and water usage
- ◆ Five-cycle control delivers controlled upflow backwash, downflow brining and slow rinse, rapid rinse, timed brine refill and downflow service
- ◆ Fiberglass-reinforced resin vessels with NSF-approved polyethylene liners guard against corrosion and optimize performance
- ◆ Single tank design for simplicity, efficiency, and space savings
- ◆ Large capacity brine tank maximizes time between salt replenishments

## INSTALLATION TIPS

- ◆ Locate equipment on a smooth, level surface.
- ◆ Maintain an air-gap at the end of the drain line.
- ◆ Secure drain line directly over floor drain or stand pipe.
- ◆ When connecting to a water heater, install a check valve on the soft water piping to prevent hot water back-up.
- ◆ When sweating/installing copper piping, protect the control valve from excessive heat.
- ◆ Check local codes for additional equipment that may be required, such as backflow prevention devices (i.e. RPZ).

# WS-30E SERIES WATER CONDITIONER

EV9980-58 • EV9980-59

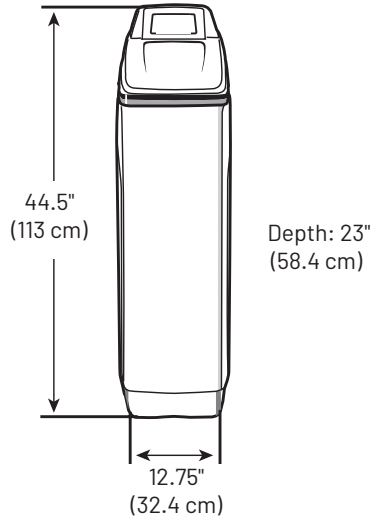

## SPECIFICATIONS

### System

**Connections**  
 Inlet Connection: 3/4" FNPT  
 Outlet Connection: 3/4" FNPT  
 Drain Line Connection: 1/2" FNPT

**Operating Pressure**  
 25 – 125 psi (1.7 – 8.6 bar)  
 non-shock

### Overall Dimensions

WS-30E (120 VAC 50/60 Hz)	44.5" H x 12.75" W x 23" D (113 cm x 32 cm x 58 cm)
WS-30E (230 VAC 50 Hz)	44.5" H x 12.75" W x 23" D (113 cm x 32 cm x 58 cm)

### Service Flow Rate

Model	Minimum Flow	@ 15 psi (1.0 bar) ΔP	@ 25 psi (1.7 bar) ΔP
WS-30E (120 VAC 50/60 Hz)	1.2 gpm (5 Lpm)	Continuous: 10 gpm (38 Lpm)	Intermittent: N/A
WS-30E (230 VAC 50 Hz)	1.2 gpm (5 Lpm)	Continuous: 10 gpm (38 Lpm)	Intermittent: N/A

### Capacity

Model	Rated Capacity	Salt Storage Capacity
WS-30E (120 VAC 50/60 Hz)	30,000 grains @ 15 lbs (7 kg) salt 24,000 grains @ 9 lbs (4 kg) salt 20,000 grains @ 6 lbs (3 kg) salt	225 lbs (102 kgs)
WS-30E (230 VAC 50 Hz)	30,000 grains @ 15 lbs (7 kg) salt 24,000 grains @ 9 lbs (4 kg) salt 20,000 grains @ 6 lbs (3 kg) salt	225 lbs (102 kgs)

### Weight

Model	Operating Weight	Shipping Weight
WS-30E (120 VAC 50/60 Hz)	550 lbs (250 kg)	90 lbs (41 kg)
WS-30E (230 VAC 50 Hz)	550 lbs (250 kg)	90 lbs (41 kg)

For Pentair Everpure Product Warranties visit:  
<http://pentair.com/assets/foodservice-warranty>

